

GREEN ENERGY SOLUTIONS

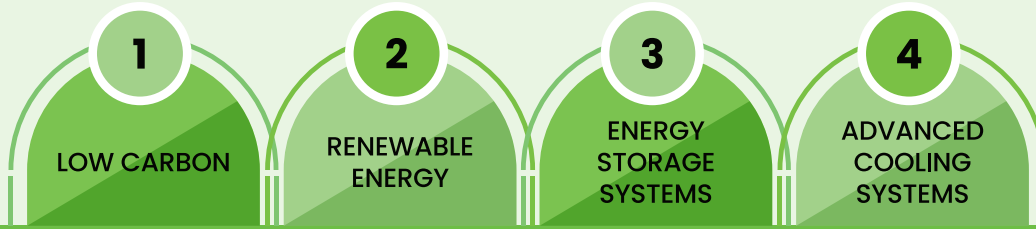

Due to the remarkable ongoing progress in clean energy and enabling technologies, the transition to a fully decarbonized electricity sector is possible. We are honoured to introduce solutions from Power Partners Group (PPG), which focuses on electricity consumption with renewable energy to support a carbon-free future. PPG can provide access to affordable clean energy products through the alternative option of the gas engine, emission control management, project planning, etc.



LOW CARBON

Co-Generation - Gas Generator / Gas Turbine / Combined Heat & Power (CHP)

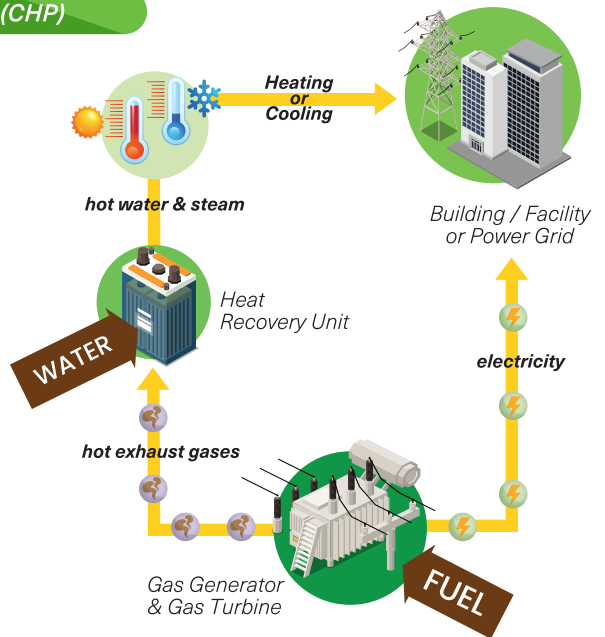
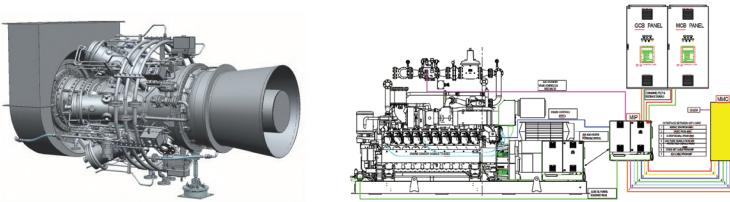

Nearly early two-thirds of the energy used by conventional electricity generation is wasted in heat discharge to the atmosphere. Additional energy is also wasted during distribution to users. By capturing this wasted heat energy and minimizing distribution losses, CHP can achieve up to 90% efficiency.

- ✓ Operational flexibility & enjoy low lifecycle costs
- ✓ 30% more power with standing hot and humid conditions
- ✓ Fast start capability - less than 120sec from 0 to 100% load

RENEWABLE ENERGY

HVO Fuel



By adopting Hydrotreated Vegetable Oil (HVO), made from vegetable waste and utilised in the same way as traditional diesel, we can contribute to climate neutrality, especially for the infrastructure industry.

- ✓ Lower NOx, PM and CO₂ emissions at nearly all load points
- ✓ Improved response to load acceptance
- ✓ Cost saving but remains full power performance
- ✓ No adjustments are required in diesel engine

Solar System

Diagram - Basic configuration of an AC coupled hybrid grid-connected power system

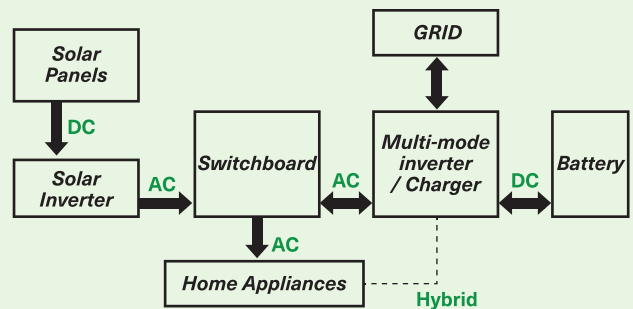

- ✓ Lower NOx, PM and CO₂ emissions at nearly all load points
- ✓ Improved response to load acceptance
- ✓ Cost saving but remains full power performance



RENEWABLE ENERGY

Hydrogen Fuel Cells & Electrolyzer

Hydrogen fuel cells are adopted by large-scale localized power generation to power homes and neighbourhoods because it could reduce power plants' energy loss. The size and cogeneration ability of fuel cells make them a great candidate for the future of centralized power grid.

Electrolyzers use electricity to break water into hydrogen and oxygen. The electrolysis of water occurs through an electrochemical reaction that does not require external components or moving parts. It is very reliable and can produce ultra-pure hydrogen (> 99.999%) in a non-polluting manner when the electrical source is renewable energy.

- ✓ Smaller footprint & fewer components
- ✓ Reduces noise and air pollution
- ✓ Scalable backup power
- ✓ Higher overall system energy efficiency
- ✓ Low TCO for wireless base stations & wireline nodes
- ✓ Longer technical lifetime (no use of power electronics)

ENERGY STORAGE SYSTEMS

Battery Energy Storage System (BESS) / Electrical Energy Storage System

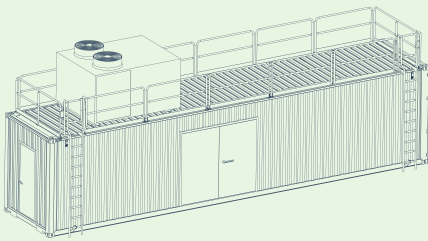

Sustainable energy is the need of the century, and ESS can store energy for later use. It also plays a distinct role in managing the discrepancy between electrical supply and demand. ESS helps to enhance grid resilience, improve utilization and increase the efficiency of hybrid systems.

- ✓ Extensive life cycle & power quality compliance
- ✓ Easy maintenance with flexible modular design
- ✓ Greater power density & control over voltage and frequency

Liquefied Natural Gas & H2 Storage System

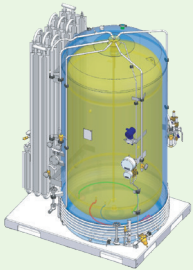

A LNG tank can have a capacity ranging from 1,000 to 30,000 m³. This system usually includes above-ground, low-pressure tanks with double walls for enhanced protection and a vacuum that provides thermal insulation to maintain the cold temperatures needed. All in all, small amounts of heat enter the system and must be safely removed periodically. Quality and safety are always demanding, from design and implementation to logistic transport and installation.

ADVANCED COOLING SYSTEMS

Air Cooling / Liquid Cooling / Immersion Cooling

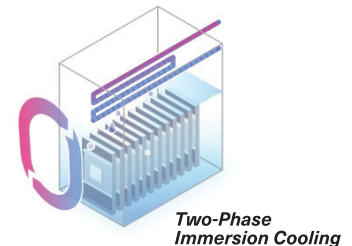
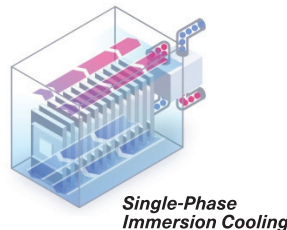
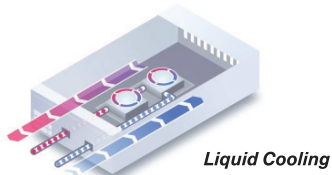
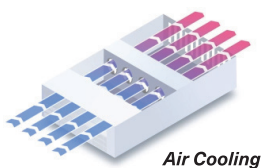

- ✓ Achieve low PUE and reduce HW failure rate
- ✓ Great saving in TCO (25-40%) & CAPEX building costs (up to 50%)
- ✓ Reduce latency and increase speed deployment
- ✓ Less power & space required

CARBON NEUTRALITY? CONTACT US FOR MORE GREEN ENERGY SOLUTIONS.